

Fashion Bed Group

A Division of Leggett & Platt Incorporated

















Part List For Contour Bed

BED CARTONS

- (11) GRILL-2
- (12) HEADBOARD POSTS-2
- (13) FOOTBOARD POST-2
- (14) FINIAL-4 (#8957Y0588)
- (15) PILLOW BAR-1
- (16) CROSS RAIL-2
- (17) SIDE RAIL-2

PART #304001 HARDWARE BAG FOR BED ASSEMBLY

- (1) 1/4-20 2 1/2" COUNTER SUNK ALLEN HEAD SCREW-10
- (2) 1/4-20 2 1/4" COUNTER SUNK ALLEN HEAD SCREW-4
- (3) 1/4-20 1" FLAT ALLEN HEAD SCREW-4
- (4) 1/4-20 HEX NUT-4
- (5) 5/8" OD FLAT WASHER-8
- (6) 7/8" OD RUBBER WASHER-8
- (7) ALLEN WRENCH
- (8) PLASTIC GLIDE-4 (#150950000)
- (9) OPEN WRENCH-1
- (10) METAL RING-8 (#30400225)

1 	2 	3 	4 	5 	6 
7 	8 	9 	10 	11 	
12 		14 	15 		
13 		16 			
		17 			

PRODUCT FULLY ASSEMBLED

HEADBOARD PANEL

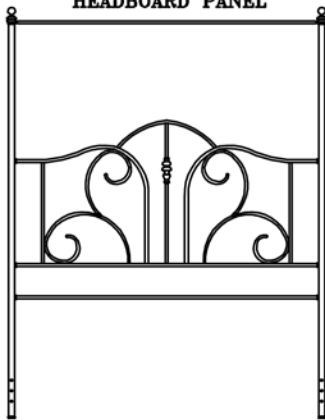

FOOTBOARD PANEL

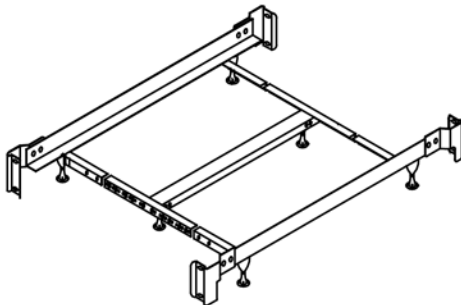
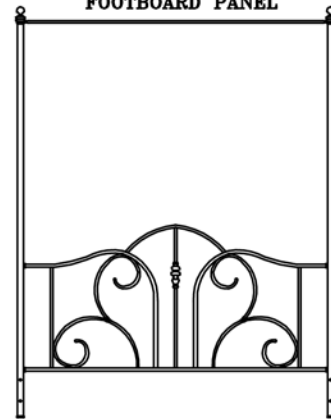

QUEEN - KING FRAME FULLY ASSEMBLED FRAMES

NOTE: SEE INSTRUCTIONS INCLUDED IN FRAME CARTON FOR FRAME ASSEMBLY

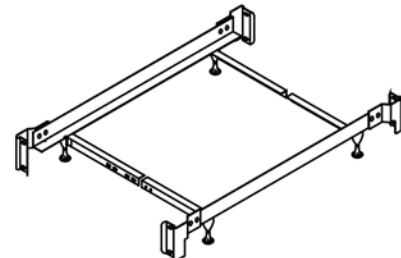

TWIN - FULL FRAME FULLY ASSEMBLED
NOTE: SEE INSTRUCTIONS INCLUDED IN FRAME CARTON FOR FRAME ASSEMBLY

Instruction Sheet

SAVE ALL PACKAGING MATERIALS UNTIL PRODUCT IS FULLY ASSEMBLED. HARDWARE AND SMALL PIECES MAY NOT BE SEEN AND BE ACCIDENTALLY DISCARDED WITH PACKAGING MATERIALS.

FIGURE 1

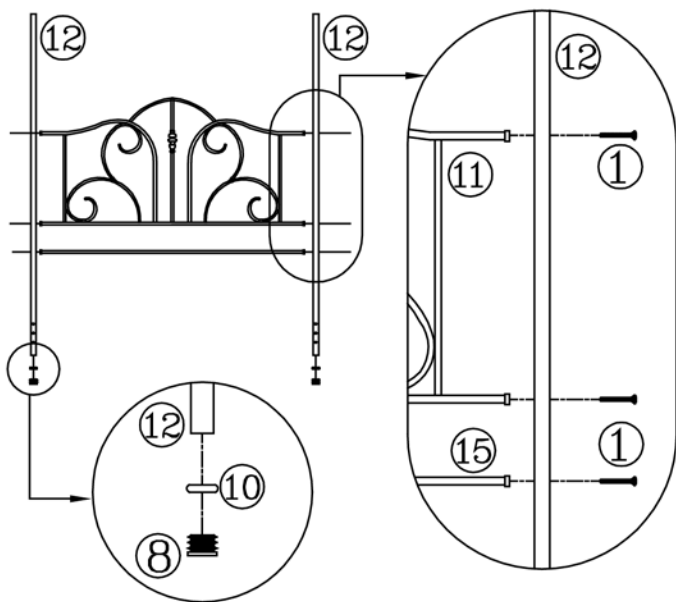

FIGURE 2

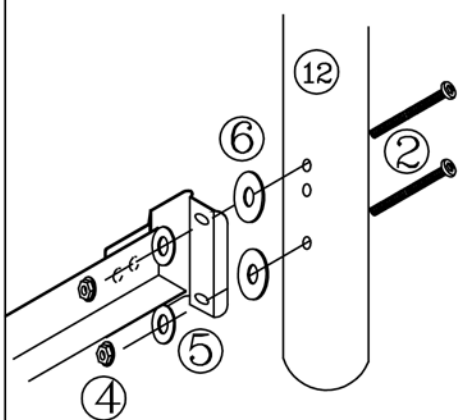
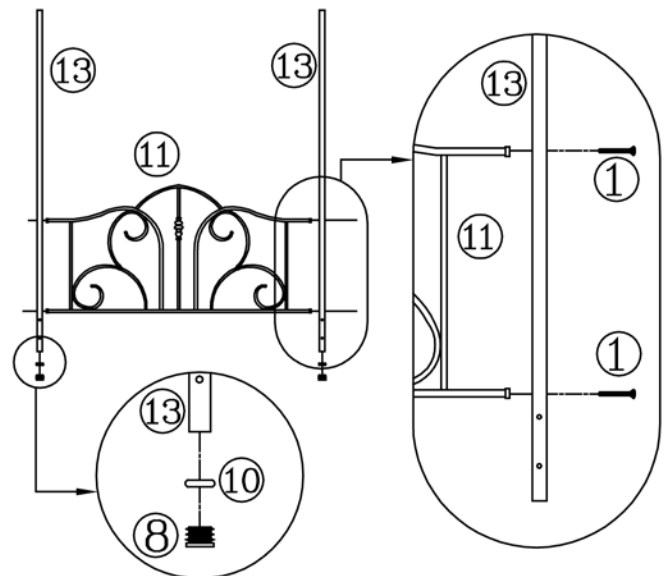

FIGURE 3

Step 1

- Slide metal rings (10) under posts (12 & 13) then insert plastic glides (8) into bottom of headboard and footboard posts. See Figure 1 & 2
- Align grill (11) rail ends and bar (15) end with holes in headboard post (12). See Figure 1
- Secure post (12) to grill (11) and bar (15) with screws (1). See Figure 1
- Repeat on other side of headboard panel.
- Tighten all screws securely using the Allen wrench.
- Repeat the same step for the footboard assembly. See Figure 2

Step 2

- Place headboard and frame in desire location in room.
- Place 2 screws (2) through holes located in post (12). (See Figure 3) Slide washers (6) over screws (2).
- Align bed frame bracket over screws.
- Place a flat washer (5) and then a nut (4) on each screw. Hand-tighten, DO NOT TIGHTEN screws all the way.
- Repeat on other side of headboard.
- Tighten all screws securely using the Allen wrench and open wrench.

Step 3

- Position footboard panel and align holes in the post (13) with holes in the frame bracket. See Figure 4
- Place flat washer (5) on each screw (3). Insert through bracket, washer (6) into post. Hand-tighten, DO NOT TIGHTEN screws all the way.
- Repeat on other side of footboard panel.
- Tighten all screws securely using the Allen wrench.

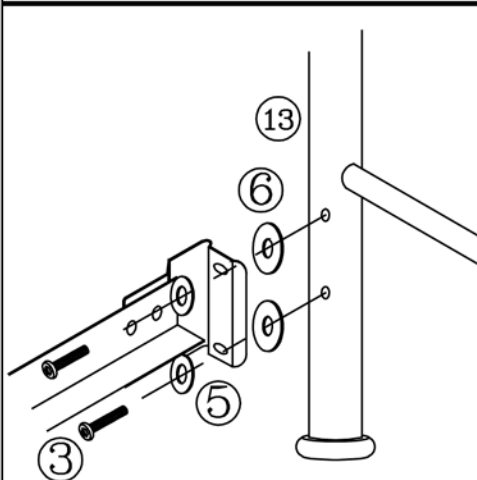

FIGURE 4

Instruction Sheet

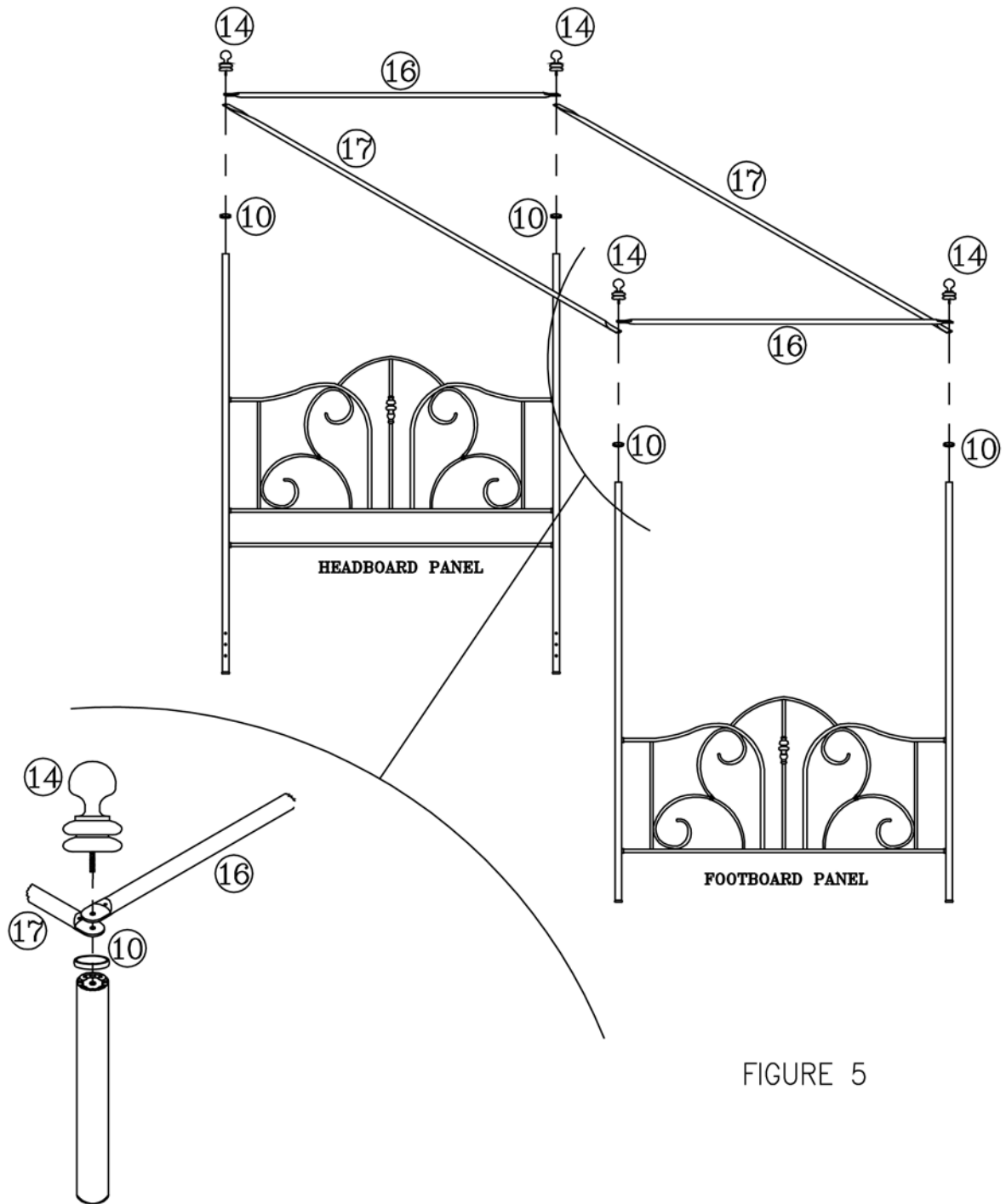

FIGURE 5

STEP 4-

Slide metal rings (10) over headboard and footboard posts. (See Figure 5)
Align end holes in Side and cross rails (17 & 16) with holes in top of bed posts.
Secure rails with finials (14) included with the bed.